

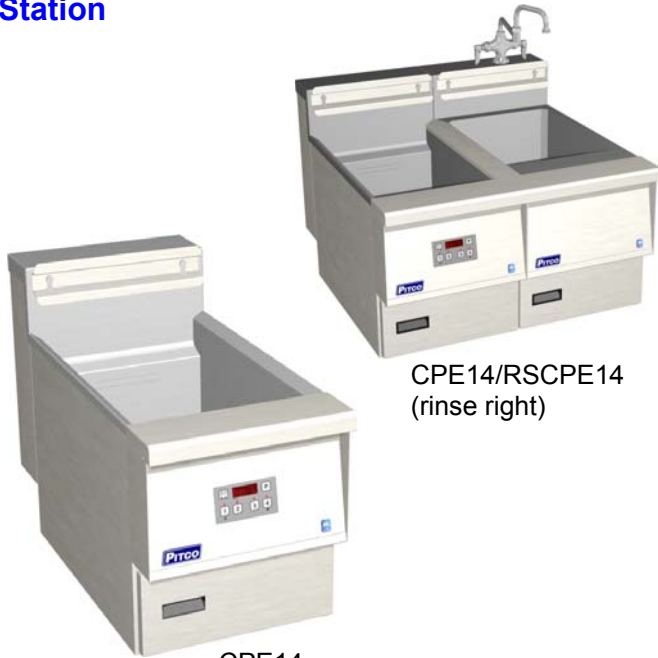

**Model CPE14, RSCPE14, CPE14/RSCPE14
Electric Counter Pasta Cooker and Rinse
Station**

Project _____
Item No. _____
Quantity _____

Model CPE14, RSCPE14, CPE14/RSCPE14 Electric Counter Pasta Cooker and Rinse Station



CPE14

CPE14/RSCPE14
(rinse right)

STANDARD FEATURES & ACCESSORIES

- Marine grade stainless steel tank
- Stainless steel exterior cabinet
- Digital Controller with 4 product key timer
- Tank overflow
- Hot/Cold Swivel Faucet (faucet can not be mounted on counter electric cooker)
- Drain clean out rod
- Element rack (cooker)
- Removable basket hangers
- Cleaner sample packet

CONTROLS

- Digital Controller with precise temperature regulation for boil and simmer modes.
- Built in Countdown timer is capable of storing 8 menu times on 4 product keys for quick starts.
- Integrated BOIL/SIMMER switch allows you to easily select the desired cooking mode
- Controller has an audible high temp alarm
- Temperature limit switch safely shuts off all heat if the upper temperature limit is exceeded.
- Redundant heating contactors for safe operation.

STANDARD SPECIFICATIONS

CONSTRUCTION

- Stainless steel tank on cooker and rinse station.
- Welded tank with an extra smooth peened finish ensures easy cleaning.
- Cabinet exterior constructed of stainless steel.
- Wide radius heating element allow access to the tank sides and bottom for deep cleaning.
- Bracket free element support eliminates hard to clean areas.
- 1" (2.6 cm) Full port quick opening drain valve.
- Tank overflow prevents the water from flowing over the side of the tank and onto the floor.
- Drain T manifold connects the cooker and rinse. drains into a single drain connection located in rear of the unit.

MODELS AVAILABLE:

- CPE14 Pasta Cooker only
- RSCPE14 Rinse Station with faucet only
- CPE14/RSCPE14 Pasta & Rinse System
Includes Rinse Station with faucet, Pasta Cooker
(Specify Rinse Location, Left or Right)

**OPTIONS & ACCESSORIES
AT ADDITIONAL COST**

- Small Bulk Pasta Basket Fine Mesh
- 6-1/4" Round Basket
- 4-7/8" Round Basket
- 4-7/8" Round Basket Fine Mesh
- Individual Serving basket (9) with Rack
- Insulated Rinse tank
- Manual Water Fill
- Drain "T" manifold cooker/rinse station
- 8 Foot Flexible Drain Extension Hose
- 6 Foot Power Cord Right Angle
(NEMA L6-50P) Domestic Units Only



Pitco Frialator, Inc • P.O. Box 501, Concord, NH 03302-0501 • 509 Route 3A, Bow, NH 03304

603-225-6684 • FAX: 603-225-8497 • www.pitco.com

L10-226 Rev 1 06/07

Printed in the USA

Model CPE14, RSCPE14, CPE14/RSCPE14 Electric Counter Pasta Cooker and Rinse Station

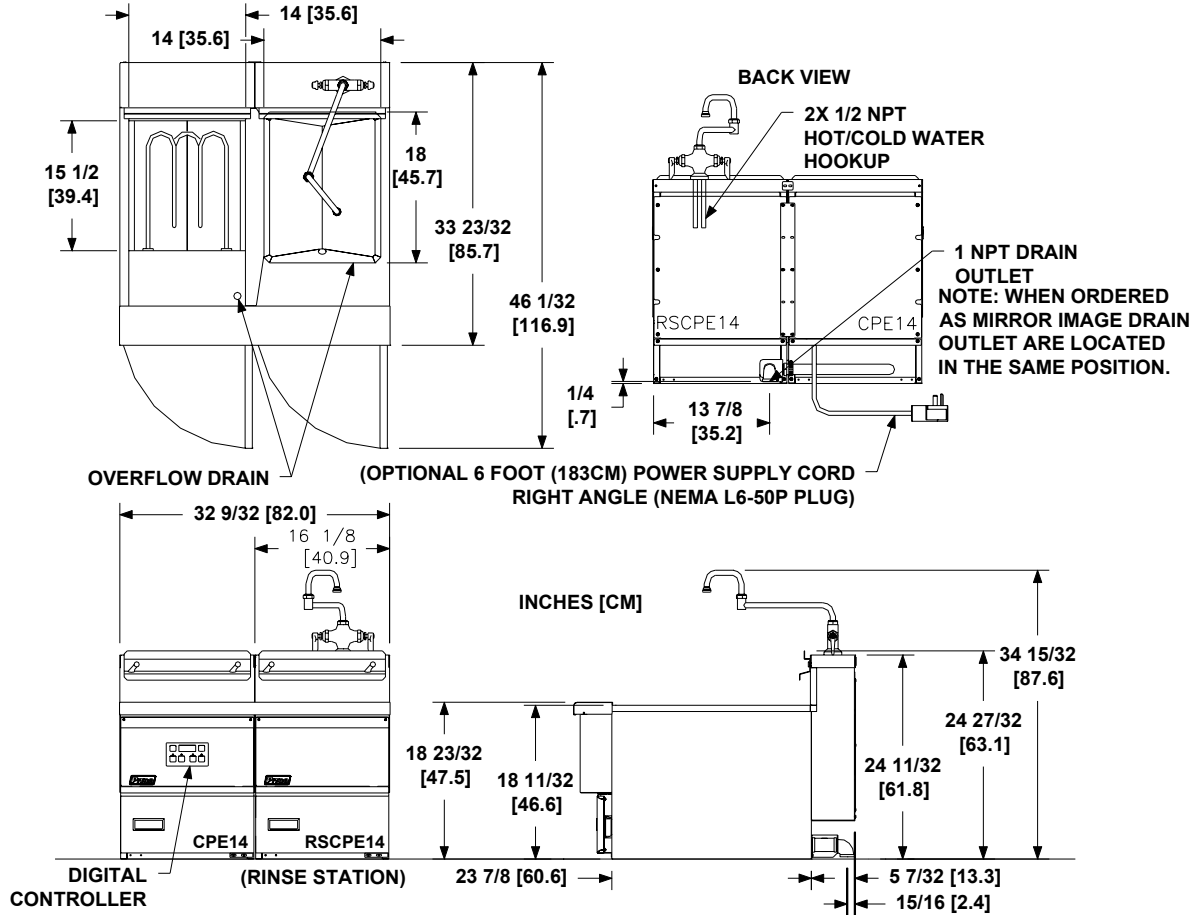

ELECTRIC COUNTER PASTA AND RINSE SPECIFICATIONS

Models	Cooking Area	Cook Depth	Water Capacity	Voltage/PH 50/60HZ	Amps	KW	MATING * RECEPTACLES
CPE14 (only available in single phase)	14" x 15 1/2" (35.5 x 39.4 cm)	8" (20.3 cm)	7 gal (26.5 liters)	208 / 1	29	6.0	Hubbell P/N's
				220 / 1	23	5.0	
				230 / 1	24	5.5	HBL9367
				240 / 1	25	6.0	
RSCPE14 (Rinse)	14" x 18" (35.5 x 46 cm)	10 3/4" (27.3 cm)		* This is for the installer to match the optionally supplied domestic cord/plug. International units are shipped without a power cord.			
				N/A	N/A	N/A	N/A

PASTA SYSTEM SHIPPING INFORMATION (Approximate)

Shipping Weight	Shipping Crate Size H x W x L	Shipping Cube
160 Lbs (72.5 kg)	44 x 42 x 52 in (111.7 x 106.6 x 132.1 cm)	55.6 ft ³ (1.6m ³)

SHORT FORM SPECIFICATION

Provide Pitco Model CPE14 Counter Top Pasta Cooker and Rinse station. Unit shall use a digital controller to boil water for cooking pasta and to maintain precise simmer temperatures for rethermalizing. Provide the ability to set electronic timer in minutes and seconds for up to 8 menu times using 4 product keys. The tank shall be constructed of type 316 stainless steel with tank overflows and hold 7 gallons (26.5 liters) of water with front 1" - (2.6cm) full port drain. Drain lines are to be manifolded to the rear into a single drain connection. Rinse tank will be equipped with a hot and cold swivel faucet. Entire cabinet exterior shall be constructed of stainless steel. Provide accessories as follows:

TYPICAL APPLICATION

High production of dry and cooked pasta for individual and bulk preparation where space is a premium. The cooker is versatile in cooking a wide variety of pastas while the rinse station is ideal for rinsing and quick chilling pasta prior to portioning into individual packages. The simmer mode is used to gently rethermalize cooked pastas or precooked foods prior to plating or pan sauteing.

