



Project \_\_\_\_\_  
 Item No. \_\_\_\_\_  
 Quantity \_\_\_\_\_

**Model SSPE14, SSRS14  
 Solstice Supreme Pasta Electric Cooker  
 and Rinse**



**Model SSPE14/SSRS14  
 Shown with option: Single Basket Lift**

**STANDARD FEATURES & ACCESSORIES**

- Marine grade stainless steel tank
- Stainless steel exterior cabinet
- Digital Controller with 4 button Timer
- Drain "T" manifold standard on SSPE14 cooker/SSRS14 rinse station.
- Faucet on Rinse
- Manual Water Fill
- Tank overflow
- Tank overflow screen
- Drain screen
- Drain clean out rod
- Element rack (cooker)
- Removable basket hanger
- Cleaner sample packet
- 9" (22.9 cm) adjustable legs, easier to clean

**STANDARD SPECIFICATIONS**

For High Production Pasta Cooker specify Pitco Model SSPE14 Electric Pasta cooker. High volume restaurants and multi-store chains can benefit from high production and lower annual maintenance and repair cost.

**CONSTRUCTION**

- Marine grade stainless steel tank on cooker and rinse station.
- Welded tank with an extra smooth peened finish ensures easy cleaning.
- Cabinet exterior constructed of stainless steel
- 1-1/4" (3.2 cm) Full port opening drain valve
- Tank overflow prevents the water from flowing over the side of the tank and onto the floor.

**CONTROLS**

- Digital Controller with precise temperature regulation for boil and simmer modes.
- Built in Countdown timer is capable of storing 4 menu items on controller.
- Integrated BOIL/SIMMER switch allows you to easily select the desired cooking mode.
- Controller has an audible high temp alarm.
- Temperature limit switch safely shuts off all heat if the upper temperature limit is exceeded.
- Low level liquid sensor.

**OPTIONS & ACCESSORIES  
 (AT ADDITIONAL COST)**

- Digital Control with 2 Button count down timer (no preset cook times)
- Regulated Mixing Valve (Includes unregulated and regulated flow knobs)
- Basket Lifts (Single or Dual)
- Rinse Tank Insulation
- 9" casters (22.9 cm)
- Small Bulk Pasta Basket Fine Mesh
- Large Bulk Pasta Basket Fine Mesh
- Oblong Basket
- 9 Individual Serving Baskets with Rack
- 6-1/4" Round Basket
- 4-7/8" Round Basket
- 4-7/8" Round Basket Fine Mesh
- 6 Foot Power Cord with Straight Blade Angle Plug (NEMA 15-50P) Domestic 3 Phase Units Only, Single Phase Units must be field wired directly.

Model SSPE14, SSRS14 Solstice Supreme Pasta Electric Cooker and Rinse



**Pitco Frialator, Inc** • P.O. Box 501, Concord, NH 03302-0501 • 509 Route 3A, Bow, NH 03304  
 603-225-6684 • FAX: 603-225-8497 • [www.pitco.com](http://www.pitco.com)

## Model SSPE14, SSRS14 Solstice Supreme Pasta Electric Cooker and Rinse

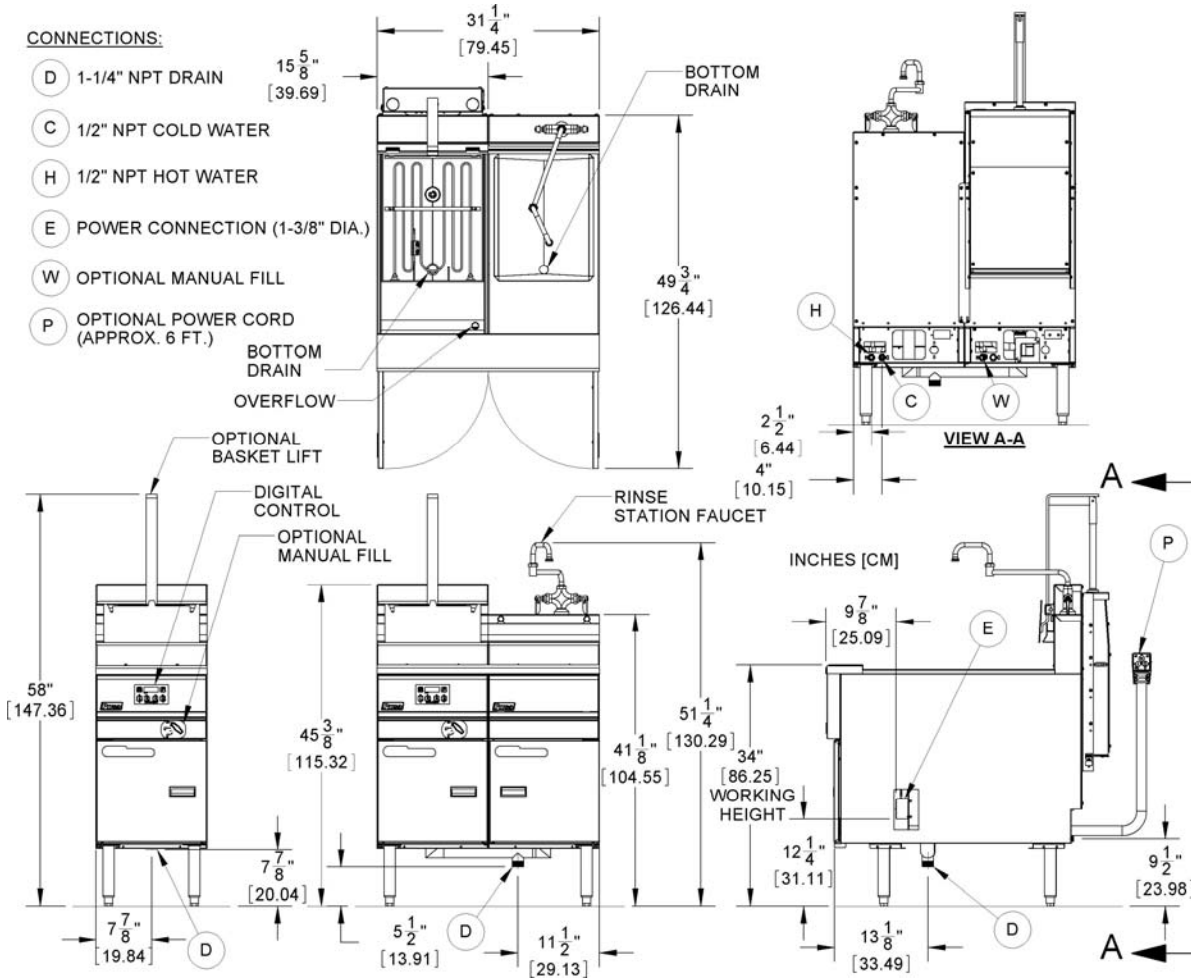

ELECTRIC PASTA COOKER and RINSE STATION SPECIFICATIONS														
Model		Cooking Area				Cook Depth				Water Capacity				
SSPE14 (Cooker)		14" x 18" (35.5 x 45.7")				11-1/4 in (28.6 cm)				12 gals (45.4 liters)				
SSRS14 (Rinse)		14" x 18" (35.5 x 45.7")				8-1/2" (21.6 cm)				10 gals (37.9 liters)				
ELECTRICAL REQUIREMENTS														
Nominal Amps Per Line (50/60HZ)	Volts	Single Phase (2 wire+ground wire)				3 Phase (3 wire+ground wire)				3 Phase "Y" (4 wire+ground wire)				
		200V	208V	220V	240V	200V	208V	220V	240V	346/200V	380/220V	400/230V	415/240V	
		KW/Hr	11.6	12.5	11.4	12.5	11.6	12.5	11.4	12.5	11.6	11.4	12.5	12.5
		Amps	58	60	52	52	33	35	30	30	19	17	18	17
<b>Note:</b> 1. Each Cooker requires its own separate power cord. 2. Pasta Cooker not available in 480V. 3. Domestic 3 Phase Units can be equipped with optional 6 Foot Power Cord with Straight Blade Angle Plug (NEMA 15-50P), Single Phase Units must be field wired directly.														
CLEARANCES														
Front min.		Floor min.				Combustible material								
30" (76.2 cm)		6" (15.25 cm)				Sides min.		6" (15.2cm)		Rear min.		6" (15.2cm)		
ELECTRIC PASTA COOKER and RINSE STATION SHIPPING INFORMATION (Approximate)														
Model	Shipping Weight	Add for Lifts	Shipping Crate Size H x W x L				Shipping Cube							
SSPE14	177 Lbs (80.3 kg)	35 lbs (16 kg)	59 x 23 x 44 in (149.8 x 58.4 x 111.7 cm)				34.6 ft <sup>3</sup> . (1.0m <sup>3</sup> )							
SSPE14/SSRS14	212 Lbs (96.2 kg)	35 lbs (16 kg)	56 x 35.5 x 46.5 in (142.2 x 90.1 x 118.1 cm)				53.5 ft <sup>3</sup> . (1.5m <sup>3</sup> )							
SSRS14 (Rinse)	136 Lbs (61.7 kg)	N/A	59 x 23 x 44 in (149.8 x 58.4 x 111.7 cm)				34.6 ft <sup>3</sup> . (1.0m <sup>3</sup> )							
SHORT FORM SPECIFICATIONS														
Provide Pitco Model SSPE14 Electric Pasta Cooker or SSRS14 Rinse Station with faucet. Cooking unit shall use a digital controller to boil water for cooking pasta and to maintain precise simmer temperatures for rethermalizing. Provide the ability to set electronic timer in minutes and seconds for 4 menu times using 4 product keys. The tank shall be constructed of marine grade stainless steel with tank overflows and hold 12 gallons (45.4 liters) of water with bottom 1 1/4"-(3.2cm) full port drain. The rinse tank shall be constructed of marine grade stainless steel with tank overflows and hold 10 gallons (37.85 liters) of water with bottom 1 1/4"-(3.2cm) full port drain. Entire cabinet exterior shall be constructed of stainless steel. Provide accessories as follows:														
TYPICAL APPLICATION														
High production of dry and cooked pasta for individual and bulk preparation where space is a premium. The cooker is versatile in cooking a wide variety of pasta. The simmer mode is used to gently rethermalize cooked pasta or precooked foods prior to plating or pan sauteing.														



**Pitco Frialator, Inc** • P.O. Box 501, Concord, NH 03302-0501 • 509 Route 3A, Bow, NH 03304

603-225-6684 • FAX: 603-225-8497 • [www.pitco.com](http://www.pitco.com) L10-338 Rev 1 08/11 Printed in the USA

We reserve the right to change specifications without notice and without incurring any obligation for equipment previously or subsequently sold.