



Project _____

Item No. _____

Quantity _____

SOLSTICE ELECTRIC (SE) Series SE14, 14T, 148 (R,X), 18 (R), 184 (R) Fryer

APPLICATION

For High Production Electric frying specify Pitco Solstice Electric Models SE14, 14T, 148 (RX) or 18 (R), 184 (R) fryers with multiple heat input (kilowatt) options for that EnergyStar™ performance to meet your frying demands. The Solstice electric fryer comes in numerous sizes to match different product frying applications and uses highly reliable fixed heating elements and environmentally friendly mercury-free contactors. For precise temperature control the fryer comes standard with a behind the door solid state thermostat with melt cycle and boil out modes. For additional timer capability the optional digital control and the elastic time computer are available and can be used with our optional labor saving highly reliable basket lift system.

MODELS AVAILABLE

SE14 Series (40-50 lbs, 14 x 14" fry area)

- SE14** 17kW/hr
- SE14R** 22kW/hr
- SE14X** 14kW/hr

SE14T Series (20-25 lbs, 7 x 14-9/32" fry area per side for this twin vat fryer)

- SE14T 17kW/hr (8.5kW per tank side)
- SE14TR 22kW/hr (11kW per tank side)
- SE14TX 14kW/hr (7kW per tank side)

SE148 Series (60 lbs, 14 x 18" fry area)

- SE148 17kW/hr
- SE148R 22kW/hr
- SE148X 14kW/hr

SE184 Series (60 lbs, 18 x 14" fry area)

- SE184** 17kW/hr
- SE184R 22kW/hr

SE18 Series (70-90 lbs, 18 x 18" fry area)

- SE18 17kW/hr
- SE18R 22kW/hr

OPTIONS & ACCESSORIES (AT ADDITIONAL COST)

- Digital Controller (2 timers w/ melt cycle & boil out mode)
- Intellifry I12 Computer (12 elastic timers w/ melt cycle & boil out)
- Backup thermostat (only on Digital and I12 computer)
- Basket Lift (must be ordered with Digital control or Computer)
- Stainless steel back (not available with basket lift)
- 9" (22.9 cm) adjustable rear and front locking casters
- Tank cover
- 3-Triple Baskets (not available on 14T)
- Consult Factory for other basket configurations
- Splash Guard reversible 6" 8" 12" 18"
- Work shelves call factory for specifications and availability.
- Fish Grids only available on SE18 and SE18R
- Institutional Prison security package
- BNB Dump Station, see BNB spec sheet for details
- Filter System Options
 - Filter Drawer see spec sheet for details
 - SoloFilter see spec sheet for details
- 6' Power Cord (14KW and 17KW 3ph, 208V or 240V 3Phase only)



SE14 (R,X)
w/ standard
SSTC

SE14T (R,X)
w/ optional
rear casters

SE148 (R,X)
w/ optional
Digital Control

SE18 (R)
w/ optional
I12 Computer &
Basket Lifts,
front / rear casters



** EnergyStar
Qualified Model

STANDARD FEATURES

- Tank - stainless steel construction
- Cabinet - stainless steel front, door and sides.
- Fixed heating elements for EnergyStar™ performance
- Solid State T-Stat (SSTC) w/melt cycle & boil out mode
- Mercury Free heating contactors
- High Temperature safety limit switch
- Drain valve interlock
- 1 1/4" (3.2 cm) Full port drain valve for fast draining
- 9" (22.9 cm) adjustable legs, easier access to clean
- Element rack
- Removable basket hanger, requires no tools
- Drain Line Clean out rod
- Fryer cleaning brush
- Fryer cleaner sample packet
- Choice of basket options:
 - 2 Twin baskets
 - 1-Full basket (not available on 14T or Basket Lifts)



SOLSTICE ELECTRIC (SE) Series SE14, 14T, 148 (R,X), 18 (R), 184 (R) Fryer



Pitco Frialator, Inc • P.O. Box 501, Concord, NH 03302-0501 • 509 Route 3A, Bow, NH 03304

603-225-6684 • FAX: 603-225-8497 • www.pitco.com

L10-146 Rev 4 08/11 Printed in the USA

SOLSTICE ELECTRIC (SE) Series SE14, 14T, 148 (R,X), 18 (R), 184 (R) Fryer

SOLSTICE ELECTRIC (SE) Series SE14, 14T, 148 (R,X), 18 (R), 184 (R) Fryer

TABLE				
MODEL	DIM A	DIM B	DIM C	DIM D
SE14,14T (R,X)	15 5/8 [39.7]	48 5/16 [122.8]	21 27/32 [39.7]	21 5/8 [39.7]
SE148 (R,X)	15 5/8 [39.7]	48 5/16 [122.8]	24 27/32 [63.1]	20 5/8 [52.4]
SE18 (R)	19 5/8 [49.8]	52 5/16 [132.9]	24 27/32 [63.1]	20 5/8 [52.4]
SE184 (R)	19 5/8 [49.8]	52 5/16 [132.9]	21 27/32 [39.7]	21 5/8 [39.7]

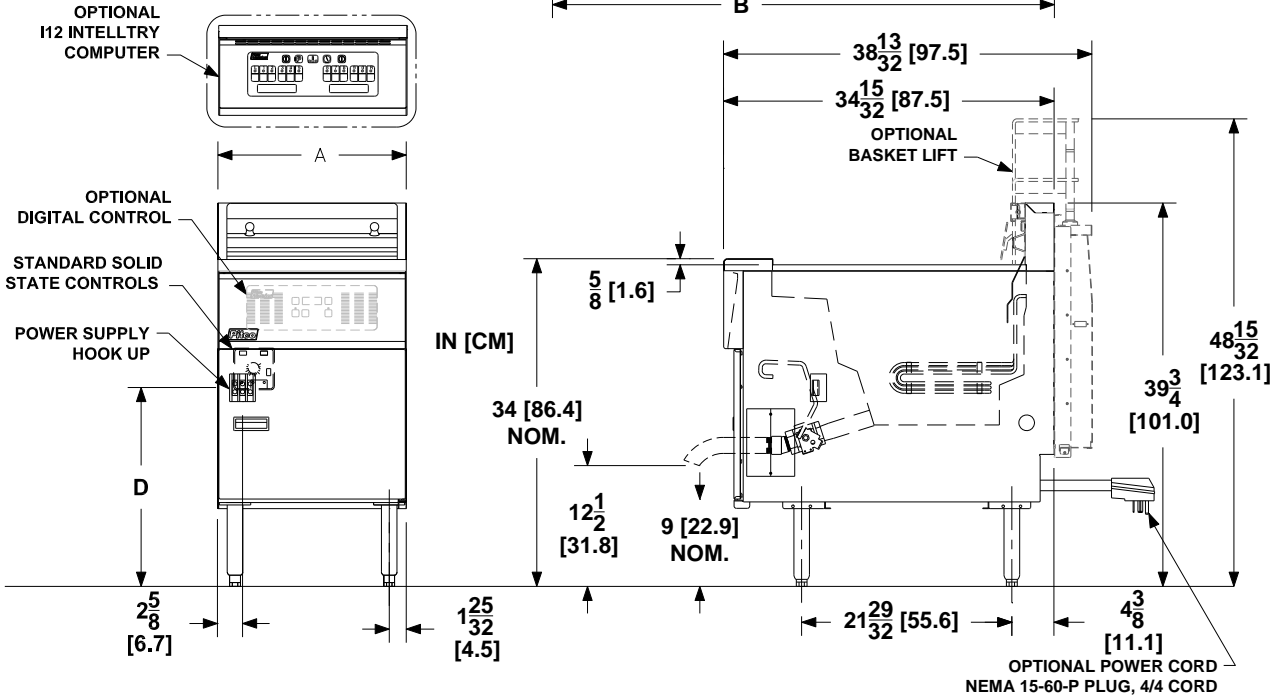

INDIVIDUAL FRYER SPECIFICATIONS			SHIPPING INFORMATION (Approximate)			
Model	Cooking Area & Depth	Oil Capacity	Shipping Weight	Shipping Weight w B/L	Shipping Crate Size H x W x L	Shipping Cube
SE (14, 14R, 14X)	14 x 14 x 4 in (35.6 x 35.6 x 10.2 cm)	40-50 lbs (18-23 kg)	200 lbs (91 kg)	250 lbs (113 kg)	45 x 19 x 36 in 114.3 x 48.3 x 91.4 cm	17.8 ft ³ 0.5 m ³
SE (14T, 14TR, 14TX) * per Tank side	7 x 14 9/32 x 4 in * (17.8 x 36.3 x 10.2 cm)	20-25Lbs * (9-11.5 kg)	230 lbs (104 kg)	280 lbs (127 kg)	45 x 19 x 36 in 114.3 x 48.3 x 91.4 cm	17.8 ft ³ 0.5 m ³
SE (148, 148R, 148X)	14 x 18 x 4 in (35.6 x 45.7 x 10.2 cm)	60 lbs (27 kg)	215 lbs (97.5 kg)	265 lbs (120 kg)	45 x 19 x 36 in 114.3 x 48.3 x 91.4 cm	17.8 ft ³ 0.5 m ³
SE (18, 18R)	18 x 18 x 4-3/4 in (45.7 x 45.7 x 12.1cm)	70-90 lbs (32-41 kg)	226 lbs (103 kg)	276 lbs (125 kg)	59 x 23 x 44 in 149.8 x 58.4 x 111.7 cm	34.6 ft ³ 1.0 m ³
SE (184, 184R)	18 x 14 x 4-3/4 in (45.7 x 35.6 x 12.1cm)	60 lbs (27 kg)	226 lbs (103 kg)	276 lbs (125 kg)	59 x 23 x 44 in 149.8 x 58.4 x 111.7 cm	34.6 ft ³ 1.0 m ³

ELECTRICAL REQUIREMENTS		Nominal Amps Per Line (50/60 HZ)											
		Single Phase (2 wire + ground)					3 Phase (3 wire + ground)			3 Phase "Y" (4 wire + ground)			
Model	KW/Hr	208V	220V	230V	240V	480V	208V	220V	240V	480V	380/220V	400/230V	415/240V
SE (14, 14T, 148, 18, 184)	17	82	78	74	71	36	48	45	41	21	26	25	24
SE (14R, 14TR, 148R, 18R, 184R)	22	106	100	96	92	46	62	58	53	27	34	32	31
SE (14X, 14TX, 148X)	14	67.3	64.7	60.9	58.3	29.2	38.9	36.7	33.7	16.8	21.3	20.2	19.5

Note: 1. Each fryer requires it's own separate power cord. 2. Power supply for Basket Lifts is wired into the fryer's high voltage line terminal block, except for 480V which requires another separate 115V (2 amp) power cord connection to the unit.

SHORT FORM SPECIFICATIONS

Provide Pitco Solstice Electric Model (SE xxx) electric fryer. Fryer shall be xx-xx lbs oil capacity, xxx kW/hr, "xx by xx" cook area, SS peened tank, stainless front, door, sides. Fixed immersion type heating elements with high temp alloy sheath, mercury-free contactors, drain valve interlock, 1-1/4" full port drain, 3/16" bottom hinge with standard behind the door solid state thermostat with melt cycle and boil out (or specify optional digital or computer controls). Provide options and accessories as follows.



Pitco Frialator, Inc • P.O. Box 501, Concord, NH 03302-0501 • 509 Route 3A, Bow, NH 03304

603-225-6684 • FAX: 603-225-8497 • www.pitco.com

L10-146 Rev 4 08/11 Printed in the USA