



**Model KF-SG6H
Gas Open Fryer with Filtration**



Model KF-SG6H Gas Open Fryer with Filtration



APPLICATION

The KF-SG6H fryer design offers higher production with an increase in burner efficiency and space savings with an "Under the Fryer Filter System". The fryer can cook up to 6 heads of Crispy or Hot & Spicy chicken, or sixty Crispy strips on four standard half size racks. Standard KFC freezer to fryer products can also be cooked using standard fryer baskets.

SHORT FORM DESCRIPTION

Fryer, Gas Open Fryer with Filtration KF-SG6H (Gas type, voltage), Line up-SG6H with filter below, KFC/FAST VC210 SG6H computer, matchless ignition, float switch, SS sides & front, casters rear/legs front crackling basket, lift assist with 1/2 rack holder. Accessories includes: (1) brush, (1) YUM 14 x 22 (35.6 x 55.9 cm) filter paper envelope starter pack, (1) 48" x 3/4" (122 x 1.9 cm) NPT flexible gas hose with disconnect, (1) tray holder bone-in rack. Startup performance check by a qualified service representative.

STANDARD FRYER FEATURES

- Fry pot constructed of stainless steel
- SOLSTICE™ Burner Technology
- 1 1/4" (3.2 cm) Full port drain valve
- Cabinet- stainless steel sides, front, splash back
- KFC/FAST VC210 SG6H cooking computer
- Matchless pilot ignition system with flame loss safety shut off, dedicated fryer gas shut-off valves
- High temperature limit switch
- Float Switch
- Heavy duty 3/16" (.48 cm) door hinges
- 10" (25.4 cm) fixed casters rear and front legs
- Single gas connection -3/4" (1.9 cm) NPT
- Lift Assist with 1/2 Rack Holder

ACCESSORY ITEMS SHIPPED WITH UNIT

- 1 - Fry pot cleaning brush
- 1 - YUM 14" x 22" (35.6 x 55.9 cm) filter paper envelope starter pack
- 1 - 48" x 3/4" (122 x 1.9 cm) NPT flexible gas hose with disconnect
- 1 - Tray Holder Bone-in Rack

STANDARD FILTER FEATURES

- Filter pump thermally and overload protected
- Rear oil return for bottom cleaning
- Extra Large 3" (7.6 cm) curved drain spout virtually eliminates splashing and swivels for oil disposal.
- Filter pan is stainless steel with rear wheels for easy movement during cleaning.
- Connection to fryer is self aligning for hands free operation.
- Self storing filter pan lid
- Crackling Basket

(OPTIONAL) START UP KIT ACCESSORIES (Ordered Separately)

- Crispy strip covers for 1/2 rack (4)
- Rack Handle (1)
- Filter shovel scoop (1)
- Fry pot crumb scoop (1)
- Fry pot drain clean out rod (1)



Pitco Frialator, Inc • P.O. Box 501, Concord, NH 03302-0501 • 509 Route 3A, Bow, NH 03304

603-225-6684 • FAX: 603-225-8497 • www.pitco.com

L10-142 Rev 8 03/12

Printed in the USA

Model KF-SG6H Gas Open Fryer with Filtration

6 FOOT (183 CM) POWER CORD (NEMA 5-15 PLUG 115VAC UNITS ONLY, OTHERWISE PLUG TO BE SUPPLIED BY END USER)

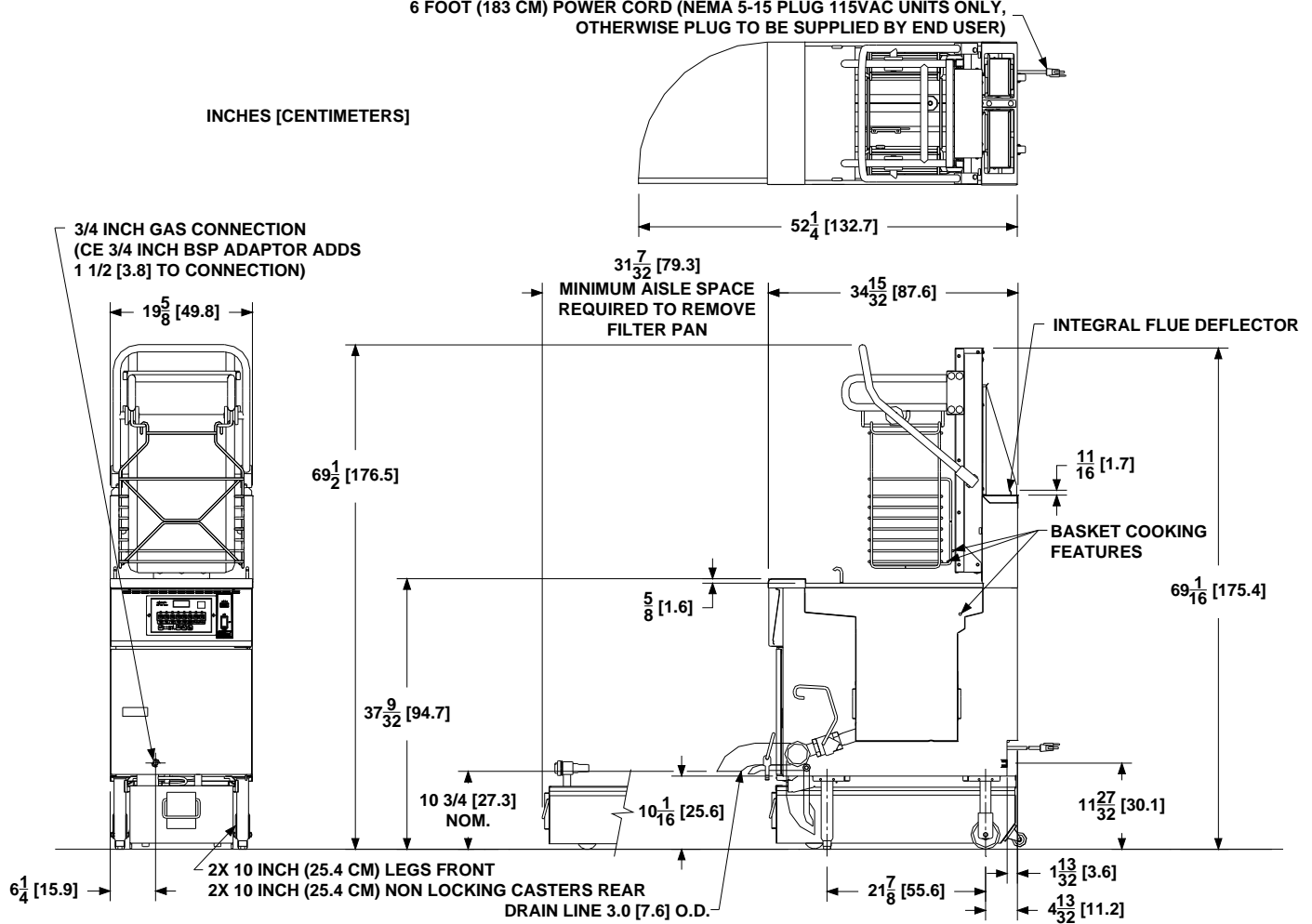

INDIVIDUAL FRYER SPECIFICATIONS

Frying Area	Cook Depth	Oil Capacity	Gas Input Rate / Hr	Burner Pressure Nat	Burner Pressure LP
14 x 18 (35.6 x 47.7 cm)	10 in (25.4 cm)	80 - 90 Lbs (36 - 40 kg)	140,000 BTUs (41 kW) (147.7 MJ)	4" W.C. (10 mbars / 1 kPa)	10" W.C. (25 mbars / 2.4 kPa)

FILTER SPECIFICATIONS

Pan Oil Capacity	Filter Pump Motor	Filter Pump Rated Flow	Filter Media
85Lbs (38 kg)	1/3 HP 50/60 Hz	8 GPM (30.3 LPM) @ 60 Hz 6.7 GPM (25.4 LPM) @ 50 Hz	14 x 22 in (35.6 x 55.9 cm) YUM Paper Envelope

(1) Energy Management System stores will need to power the fryer system for 1 hour to allow heaters to melt solid shortening in return lines and pump prior to filtering.

FRYER SYSTEM SHIPPING INFORMATION

Shipping Weight	Shipping Crate Size H x W x L	Shipping Cube
480 Lbs (218 kg)	74 x 31 x 45 in (187.9 x 78.7 x 114.3 cm)	60 ft ³ . (1.7 m ³)

INSTALLATION INFORMATION

GAS SYSTEM REQUIREMENTS			ELECTRIC SYSTEM REQUIREMENTS		
	Natural Gas	LP Gas		115V 60Hz	208 / 220-240V 50-60 hz
Supply Pressure *	7 - 10" W.C. (17.4 mbars / 1.74 kPa)	11 - 13" W.C. (27.4 mbars / 2.74 kPa)	Fryer / Filter Cord (Total Amps)	6.1	3.1
Total Gas Load / Hr	140,000 BTUs (41 kW) (147.7 MJ)				
* Check plumbing / gas codes for proper gas supply line sizing to sustain burner pressure when all gas appliances are full on.					

CLEARANCES

Front min.	Floor min.	Fryer Sides, Rear, Bottom to any combustible material	Fryer Flue Area
31 7/32" (79.3 cm)	6" (15.25 cm)	6" (15.2 cm) minimum. Do not Curb Mount.	Do not block / restrict flue gases from flow ing into hood or install vent hood drains over the flue.



Pitco Frialator, Inc • P.O. Box 501, Concord, NH 03302-0501 • 509 Route 3A, Bow, NH 03304

603-225-6684 • FAX: 603-225-8497 • www.pitco.com

L10-142 Rev 8 03/12

Printed in the USA